



Stratasys

Materials Testing Procedure

Process for printing and testing materials used in the creation of the Material Technical Data Sheets.
This document applies to the following materials:

- ABS-ESD7™
- ABS-M30™ - black
- ABS-M30i™
- ABS-CF10
- Antero™ 800NA
- Antero™ 840CN03
- ASA - black
- Diran™ 410MF07
- FDM™ Nylon 12CF
- FDM™ Nylon 12
- PC
- PC-ABS
- ULTEM™ 9085 resin - natural and black
- ULTEM™ 1010 resin*

*This material requires extra processing, steps can be found in the appendix.



Mechanical Properties

Test Samples and Parameters

Mechanical test samples were printed ten (10) samples per machine utilizing three (3) different machines, resulting in thirty (30) total samples per test for each orientation. Both on-edge (XZ) and upright (ZX) (Figure 1) orientations were tested.

Tensile mechanical tests were performed to ASTM D638 Type I samples, thickness = 3.3 mm (0.130 in.) tested with a cross-head speed of 0.2 in./min.

Flexural mechanical tests were performed to ASTM D790 samples, 12.70 mm x 3.175 mm x 76.20 mm (0.5 in. x 0.125 in. x 5 in.), using Procedure A with a span length of ~2 in. and a 0.01 in./in./min strain rate.

Compression strength tests were performed to ASTM D695 rectangular prism samples, 12.7 mm x 12.7 mm x 25.4 mm (0.5 in. x 0.5 in. x 1 in.), with a cross-head speed of 0.05 in./min. Failure was determined at the first tear in the sample.

Compression modulus tests were performed to ASTM D695 using rectangular prism samples, 12.7 mm x 12.7 mm x 25.4 mm (0.5 in. x 0.5 in. x 2 in.), with a cross-head speed of 0.05 in./min.

Izod notched tests were performed using ASTM D256 samples, thickness = 3.175 mm (0.125 in.), with a 2 ft*lb pendulum capacity using Method A. The notch was created after printing per ASTM D256.

Izod notched tests were performed using ASTM D4812 samples, thickness = 3.175 mm (0.125 in), with either a 2 or 5 ft*lb capacity.

All samples were conditioned for a minimum of 40 hours at 23 ± 2 °C (73 °F ± 3.6 °F) and $50 \pm 10\%$ RH prior to testing.

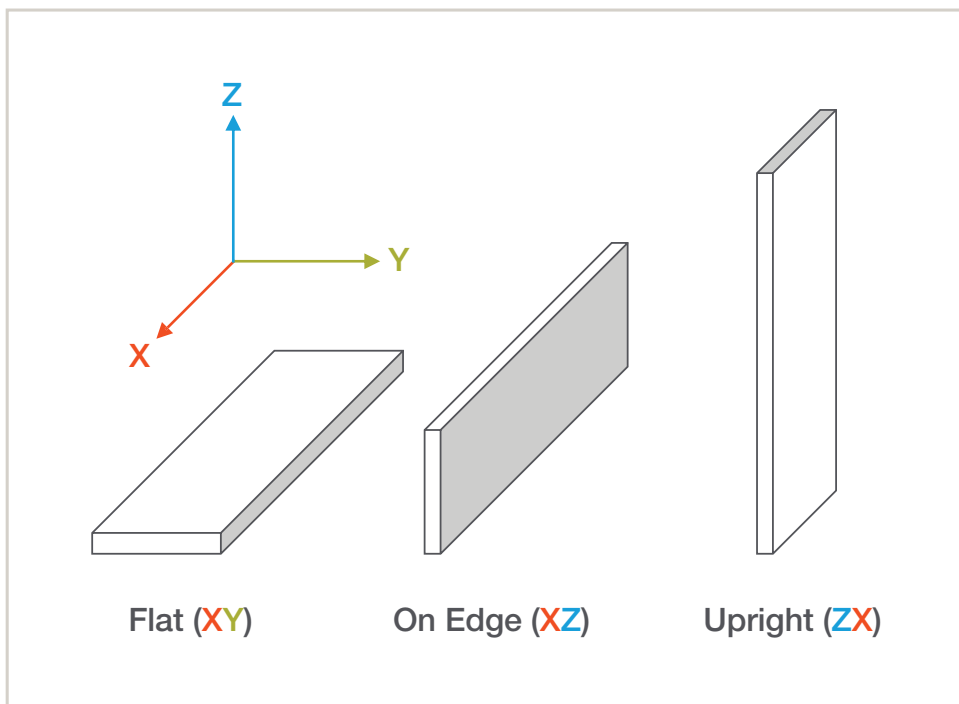

Figure 1: Print orientations.

Insight Processing

All STL files included only one sample. Each was individually processed and then copied in Control Center™.

Processing All On-Edge (XZ) Samples and Upright (ZX) Compression Samples

The STLs were processed using single contour and +45/-45 solid rasters, which are typical default settings. After the samples were sliced, and support and toolpaths were generated, seam control was used to ensure the seams were on the corners of the specimen out of the areas of concern for testing (Figure 2). Once the printer, material, and slice height were set, the CMB file was saved and exported to Control Center.

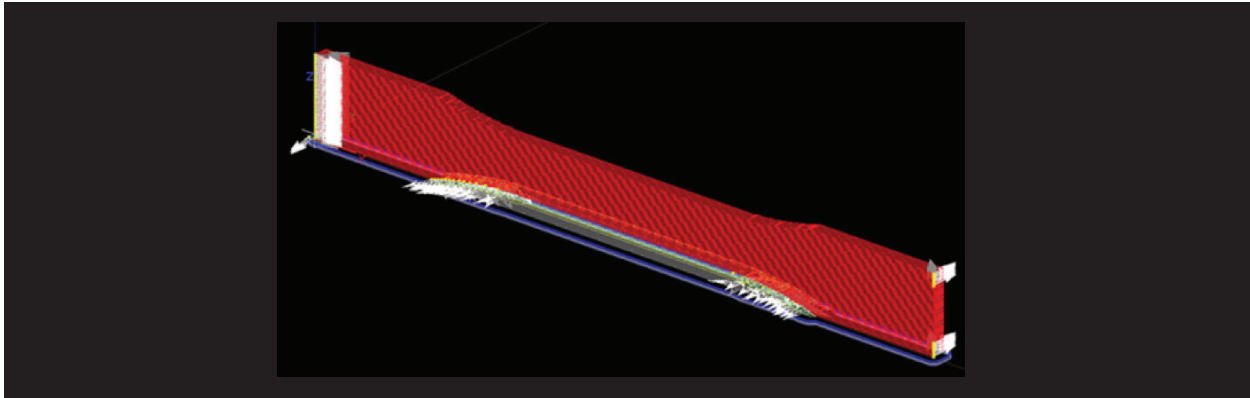

Figure 2: Seam control for an XZ tensile sample. Seams were placed on corners away from the gauge area. Seams are shown by white and gray arrows. The seams under the sample are for support and not part of the finished model.

Processing Upright (ZX) Tensile, Flexural and Izod Samples

The STL was sliced and support was generated starting with single contour and +45/-45 solid rasters, which are typical default settings. A stabilizer wall was added to the top layer of the sliced STL, starting and ending at the corners on one side of the sample (Figure 3). The parameters used to add the stabilizer wall are in Figure 4.

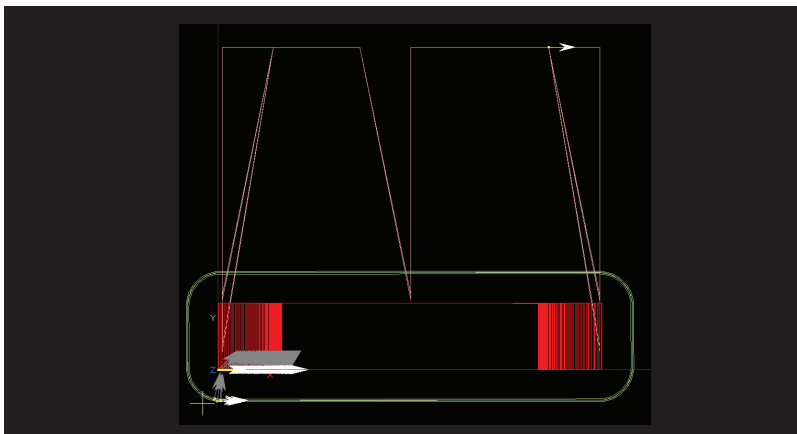

Figure 3: Stabilizer wall on an upright tensile sample. Seams are shown by gray and white arrows, originating from the bottom left corner of the sample.

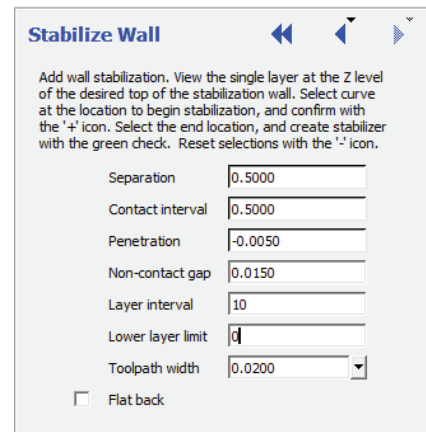

Figure 4: Stabilizer wall parameters for tensile and Izod tests.

After the stabilizer wall was added, toolpaths were generated. Seam control was used to place the seams on the front left corner away from the stabilizer wall (Figure 3). The CMB file was saved and exported to Control Center.

Seam Control

To select seam control in Insight™, go to *Insight> Toolpath> Seam control* (Figure 5).

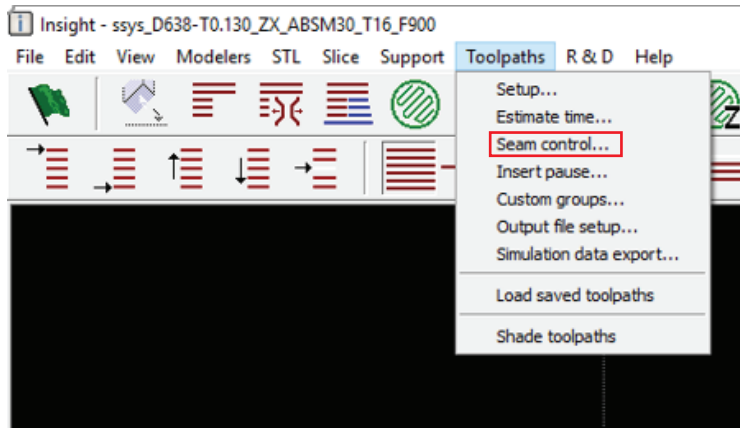

Figure 5: Seam control option in Insight, boxed in red.

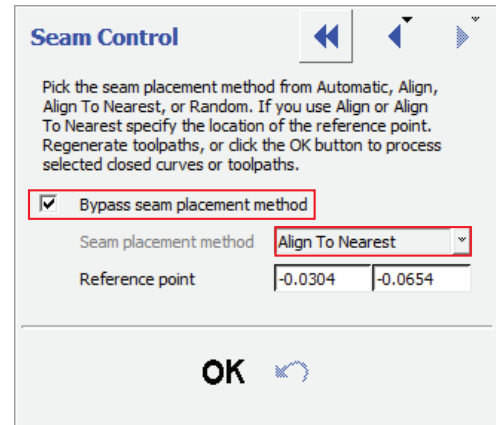

Figure 6: Selections made in Seam Control, located on the right side of the screen.

This function is easiest to use when using a top down view of your part, example in Figure 3. Select the option **Align To Nearest** in the drop down menu on the right side of the screen. After that, check the box labeled **Bypass seam placement method** (Figure 6). Then, click on a reference point by the corner you wish to align your seams on. Now you can select all the seams by dragging your mouse across the entire part. Once everything is selected (shown by the slices turning white) click on the 'OK' button on the right side of the screen. The part can now be saved and converted into a CMB file and exported to the printer.

Control Center

Each set of 10 mechanical test specimens were printed independently. When the CMB file is imported into Control Center, it is copied nine times and packed with the default packing arrangement in the center of the build area, except for tensile ZX samples. Tensile ZX samples were packed according to Figure 7. A sacrificial tower was added and built to the height of the model.

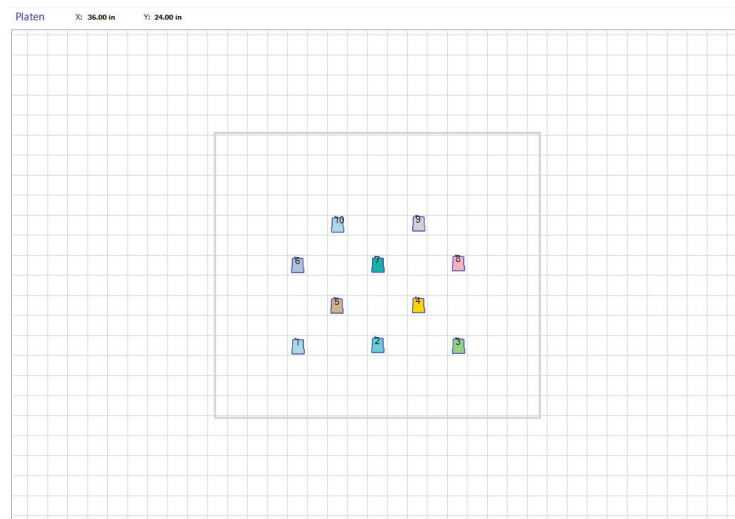

Figure 7: Control Center pack for ZX tensile samples.

Post Processing

Support was broken off the samples manually after removal from the printer, except for FDM Nylon 12CF and FDM Nylon 12. Those samples were tanked in water with P400SC WaterWorks™ cleaning solution at 50 °C (122 °F) for four hours, then removed to dry overnight.

Physical Properties

Heat Deflection Temperature (HDT): ASTM D648

HDT tests were performed using 127 mm x 12.7 mm x 3.18 mm (5 in. x 0.5 in. x 0.125 in.) samples, printed in the flat (XY) and on-edge (XZ) orientations, each orientation tested at 66 psi and 264 psi. Three samples were tested per orientation per pressure following ASTM D648 Procedure B.

Glass Transition Temperature (T_g): ASTM D7426

DSC analysis was performed using approximately 10 mg samples cut from printed flat (XY) plaques. Samples were ramped at 10 °C/min from -70 °C to the material T_g + 150 °C for the first heating scan, cooled to -70 °C, and reheated to the material T_g + 150 °C. Nitrogen was used as the purge gas. The inflection point of the 2nd heating curve was used to determine T_g.

Coefficient of Thermal Expansion (CTE): ASTM E831

TMA analysis was done using approximately 5mm square samples cut from XY and XZ plaques, printed solid with 45-45 rasters. Samples were analyzed through the thickness of the material. CTE data for XY samples is determined by measuring the expansion through layers in the Z direction; data for XZ/ZX samples measures CTE in-plane to the layers (Figure 8). Samples were heated at 5 °C/min from -50 °C to 200 °C. Force and preload were 0.1 N. The purge gas was nitrogen at a flow rate of 150 cm³/min.

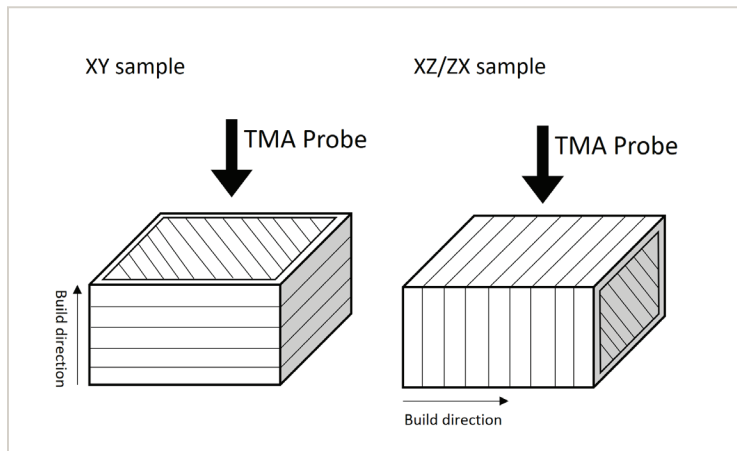

Figure 8: CTE measurements for printed FDM thermoplastics.

Volume Resistivity: ASTM D257

Volume resistivity was measured using 90 mm x 90 mm x 3.18 mm (3.5 in. x 3.5 in. x 0.125 in.) XY printed plaques. Measurements were taken with guarded parallel plate electrodes, with 500 V applied voltage for 60 seconds.

Dielectric Constant/Dissipation Factor: ASTM D150

Dielectric Constant and Dissipation Factor were measured on 76.2 mm x 76.2 mm x 3.18 mm (3 in. x 3 in. x 0.125 in.) plaques printed in both the XY and ZX/XZ orientations. Samples in each orientation were tested at 1 kHz and 2 MHz, with guarded parallel plate electrodes and an applied voltage of 5.0 V. Measurements for materials more conductive than 10⁹ Ω can not be taken.

Specific Gravity: ASTM D792

Samples were cut from unprinted filament, approximately six inches long. Room temperature water was used as the displacement fluid. Three samples per material were tested.

Appendix: ULTEM™ 1010 resin

ULTEM™ 1010 resin was tuned for longer toolpaths and the ZX orientation requires extra processing steps in order to print useful mechanical samples. For XZ mechanical samples and all physical property samples the process detailed in the main document apply.

Processing Upright (ZX) Tensile, Flexural and Izod Samples

The STL is sliced and support generated starting with default settings. Two stabilizer walls were added to the top layer, starting and ending at the corners on both sides (Figure 9). The parameters used to add the stabilizer walls are in Figure 4. Anchor columns were added to both ends of the tensile, flexural, and impact samples on the bottom layer (Figure 9). An anchor column was added to each corner of compressions samples (Figure 10).

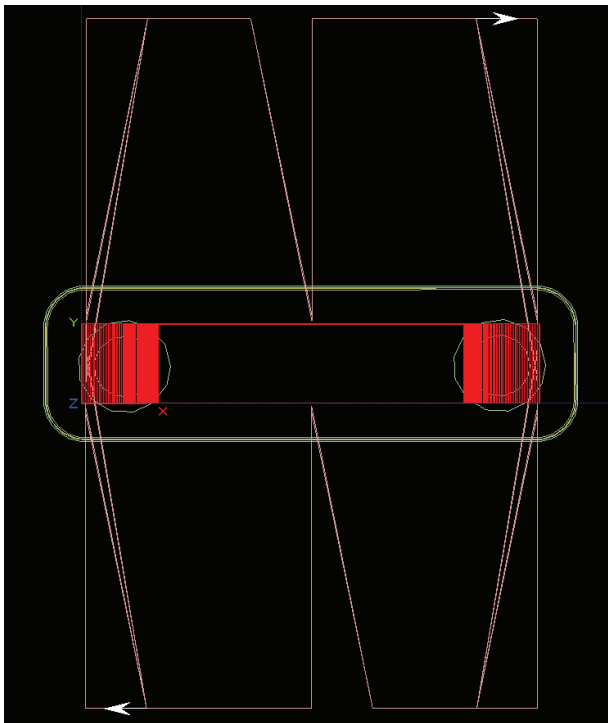

Figure 9. Stabilizer walls and anchor columns on an upright tensile sample. Seams are shown by gray and white arrows, originating from the bottom left corner of the sample.

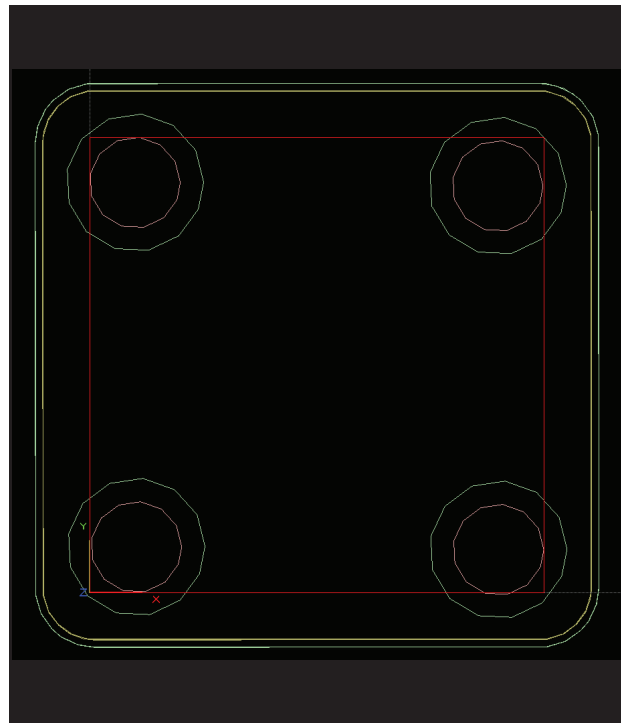
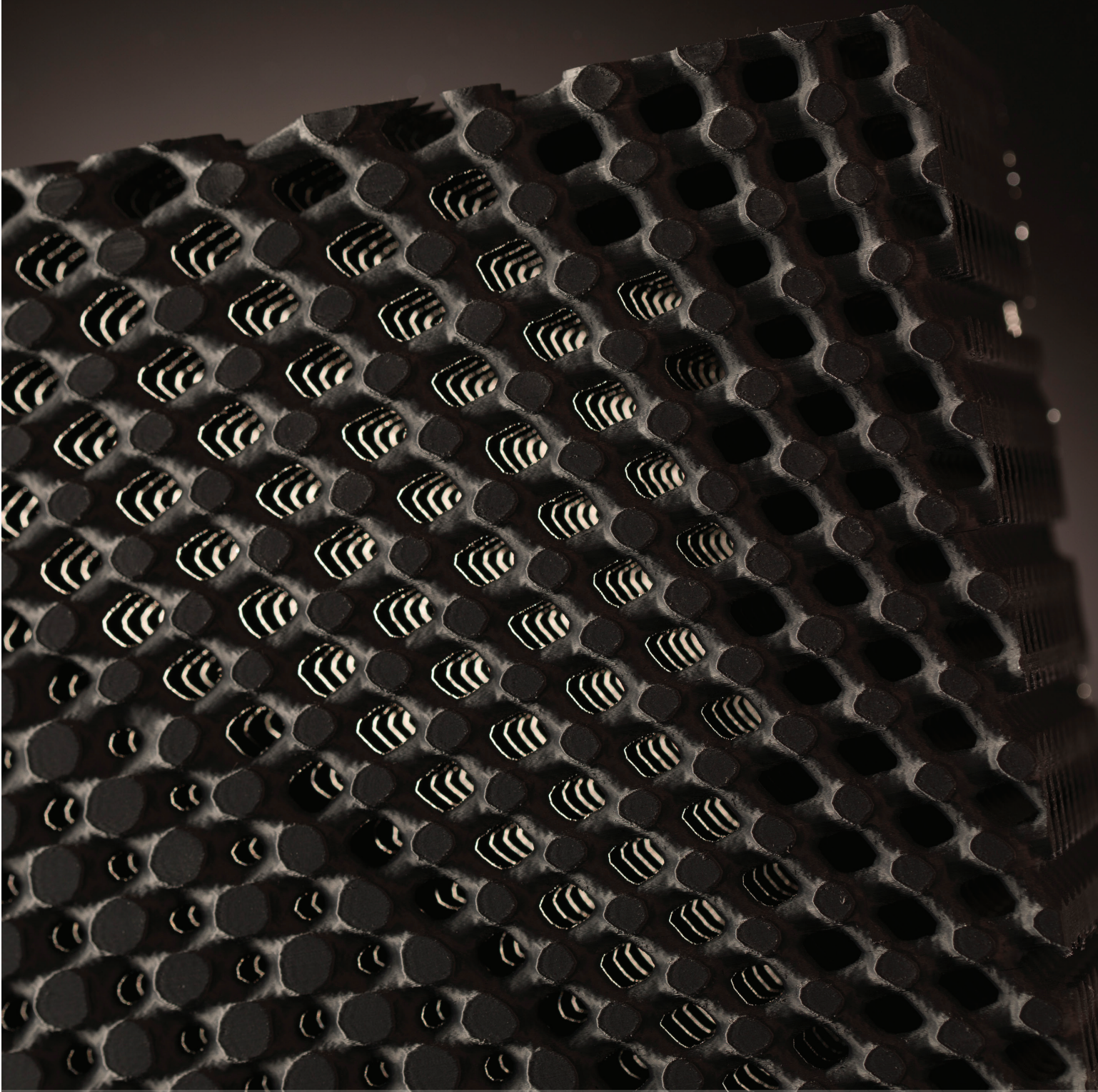

Figure 10: Anchor column locations on an upright compression sample.

After the stabilizer walls and anchor columns were added, toolpaths were generated using the default settings. Seam control was used to place the seams on the front left corner away from the stabilizer wall (Figure 3). The CMB file was saved and exported to Control Center.

Control Center

Each set of 10 mechanical test specimens were printed independently. For XZ samples, when the CMB file is imported into Control Center, it is copied nine times and packed with the default packing arrangement in the center of the build area. For ZX samples, when the CMB file is imported into Control Center, it is copied nine times and packed according to Figure 7. A sacrificial tower was added and built to the height of the model.



IME TRADING SDN BHD 198701004483
A member of IME Group of Companies

Selangor : 30A, Jln PJS 1/46, Tmn Petaling Utama, 46000 Petaling Jaya, Selangor, Malaysia.	+603-7783 6866
Penang : 68, Jln Perai Jaya 4, Bandar Perai Jaya, 13700 Pulau Pinang, Malaysia.	+604-399 5571
Johor : 25-01, Jln Bestari 8/2, Tmn Nusa Bestari, 79150 Iskandar Puteri, Johor, Malaysia.	+607-238 7978
Kuching : Private Office Suite No. 1, TEGAS Digital Village, Lot 3500, Sama Jaya High Tech Park, Block 12, Muara Tebas Land District, 93350 Kuching, Sarawak.	+6019-354 5747

3dprint.cadcam.com.my | info.3dp@cadcam.com.my

